

Dennard 2010/2015



DENNARD 2010/2015 CAMERA HOUSINGS

The DM2010 and DM2015 are designed to provide the installer with a quick, secure and reliable camera option for fixed and zoom cameras.

Ideal for any application, the robust, IP66 rated die-cast Aluminum housing provides the camera with the necessary protection from a demanding environment.

The internal camera cavity is simply accessed by loosening 3 screws (2010) 4 screws (2015) with cable conduits led out through either full or semi cable managed bracketry.

Both housings are designed to operate for either 12VDC to 24VAC or 110VAC to 230VAC.

The 2015 has been designed to provide all the features of the 2010, but the increased capacity makes it possible to incorporate a wider selection of zoom cameras. The optional wiper module adds increased functionality to meet the demands of a high specification installation.

So not only do they look good, the 2010 and 2015 are designed to reduce installation times at a competitive price.

FEATURES

- ▶ Robust IP66 rated enclosure
- ▶ Fully cable managed (2015 only)
- ▶ Demisting Heater fitted as standard
- ▶ Optional wiper module (2015 only)
- ▶ Robust die-cast Aluminium housing
- ▶ Multiple voltage option
- ▶ 2 year warranty
- ▶ compatible with most camera options
- ▶ Alocrom, Powder coated and stoved finish

ACCESSORIES	
2015	2010
DM/94033 = 2015 WIPER UNIT 230V	DM/94027 = 2010 HEATER 110-230V
DM/94034 = 2015 WIPER UNIT 110V	DM/94028 = 2010 HEATER 12-24V
DM/94035 = 2015 WIPER UNIT 24V	DM/94029 = 2010 ANTI-TAMPER SWITCH
DM/94039 = 2015 ANTI-TAMPER SCREWS	DM/94030 = 2010 FAN BRACKET ASSEMBLY
DM/94040 = 2015 ANTI-TAMPER SWITCH	DM/94039 = 2010 ANTI-TAMPER SCREWS
DM/94054 = 2015 HEATER ASSEMBLY 12-24V	
DM/94055 = 2015 HEATER ASSEMBLY 110-230V	
DM/94056 = 2015 FAN ASSEMBLY	

SPECIFICATION

MATERIAL

Pressure die cast Aluminium alloy

FINISH

Alocrom, Powder coated and stoved

HEATER VOLTAGES

12V to 24V or 110V to 230

WEIGHT

2010 - 2.2kg

2015 - 5.4kg (with wiper)

POWER CONSUMPTION

2010 - 10 Watts

2015 - 16 Watts (with wiper)

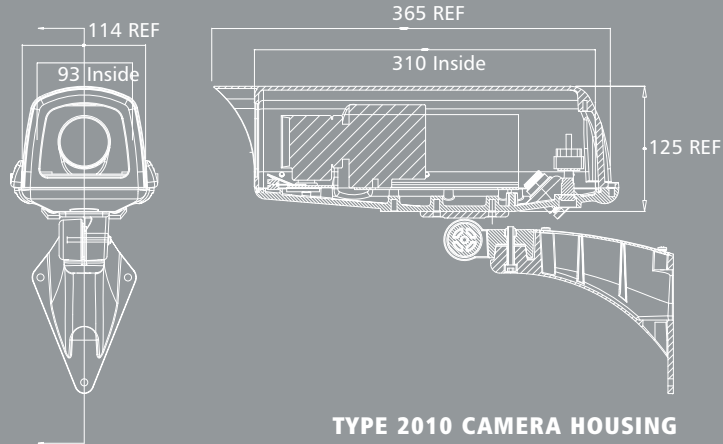

TYPE 2010 CAMERA HOUSING

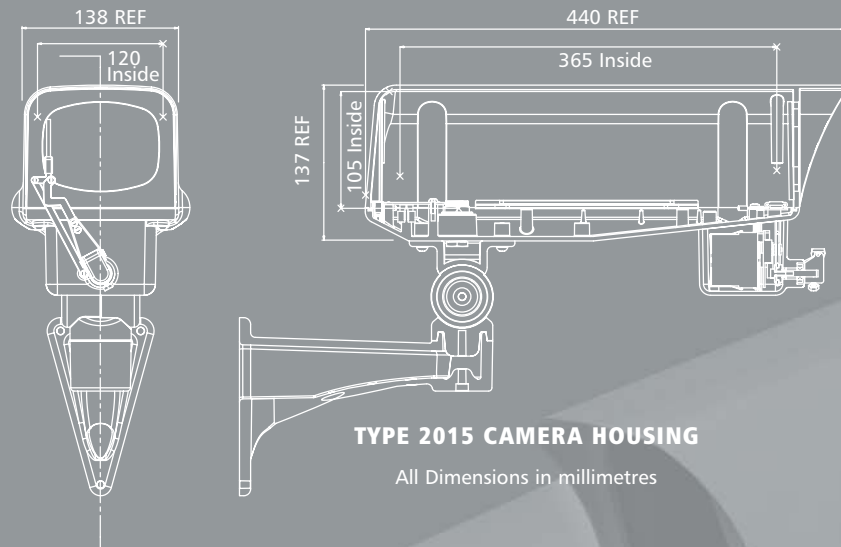

TYPE 2015 CAMERA HOUSING

All Dimensions in millimetres

PLEASE CHECK THE WEBSITE FOR DETAILS OF COMPATIBLE PRODUCTS AND OTHER LATEST DEVELOPMENTS

FOR FURTHER INFORMATION PLEASE CONTACT

Dedicated Micros UK
Dedicated Micros USA

11 Oak Street, Swinton, Manchester M27 4FL UK Tel: +44 (0) 161 727 3200 Fax: +44 (0) 161 727 3300.
14434 Albemarle Point Place, Suite 100, Chantilly, Virginia 20151 USA Freephone: 800 864 7539
Tel: +1 703 904-7738 Fax: +1 703 904-7743 and 23456 Hawthorne Blvd. Suite 100, Torrance, CA 90505,
Tel +1 310 791-8666 Fax: +1 310 791-9877.

Dedicated Micros Germany
Dedicated Micros France
Dedicated Micros Asia
Dedicated Micros Australia
Dedicated Micros Malta
Dedicated Micros Middle East

Neckarstraße 15, 41836 Hückelhoven, Germany Tel: +49 243 352 580 Fax: +49 24 33 52 58 10.
9-13 rue du Moulinet, 75013 Paris, France Tel: +33 1 45 81 99 99, Fax: +33 1 45 81 99 89.
16 New Industrial Road, #03-03 Hudson Techno Centre, Singapore 536204 Tel : +65 62858982 Fax : +65 62858646.
5/3 Packard Avenue, Castle Hill, NSW 2154, Australia Tel: +612 9634 4211 Fax: +612 9634 4811.
UB 2, San Gwann Ind. Est., San Gwann, Malta Tel: +356 21483 673 Fax: +356 21449 170.
Building 12, Suite 302, P.O.Box 500291, Dubai Internet City, Dubai, United Arab Emirates
Tel: +971 (4) 390 1015, Fax: +971 (4) 390 8655.
Delavska cesta 24, 4208 Sencur, Slovenia Tel: +386 4 279 18 90 Fax: +386 4 279 18 91.
Joseph Chantraineplantsoen 1, 3070 Kortenberg, Belgium Tel: +32 2751 3480 Fax: +32 2751 3481.

Dedicated Micros Slovenia
Dedicated Micros Benelux



www.dedicatedmicros.com

The manufacturer reserves the right to change the specification without notice.



All trademarks are courtesy of registered owners.
The DM logo is a trademark of Dedicated Microcomputers group Ltd.
MKT-201X-D-001E